

USER MANUAL

LASERGUIDE TC/PRO

- R.45.TC
- R.45.TC.PRO
- R.45.PRO-V2

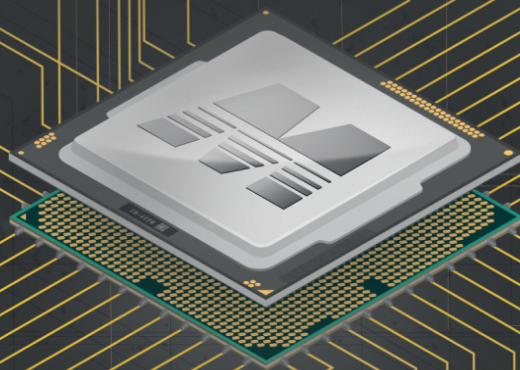

This manual is an important part of your purchase. Please read it thoroughly before using your new equipment.

We recommend that you record details of your purchase here so that the information is readily available if you ever need to contact your supplier.

Serial number

Date of purchase

Purchased from

Telephone

Email

Published by:

MOBA Mobile Automation Australia Pty Ltd
90 Willandra Drive
Epping, 3076
Victoria, Australia

Copyright © MOBA Mobile Automation Australia Pty Ltd

MCE Lasers® is a registered trademark of MOBA Mobile Automation Australia Pty Ltd

All rights reserved. No part of this manual may be reproduced in any form or by any means without prior written permission from the publishers.

February 2026

Document number: OM.R45TC.18



MCE Lasers was acquired by MOBA in 2018, bringing 40 years of Australian development and manufacturing together with MOBA's globally recognised and trusted expertise in mobile automation technology.



STATEMENT OF LIMITED WARRANTY

MOBA Mobile Automation Australia Pty Ltd (MOBA Australia) warrants all equipment it manufactures and sells to be free of defects in material and workmanship for a period specified below. This warranty period is from the date of sales invoice. All other components not manufactured by MOBA Australia and not specified below, such as hydraulic or electrical components, hoses, fittings and clamps, will carry the original manufacturer's warranty. The warranty covers only equipment sold by MOBA Australia and its authorised dealers and does not cover parallel imports, which are also known as grey or direct imports. Proof of purchase will be required before claiming warranty.

The warranty does not cover normal wear and tear or deterioration. Any evidence of negligence or abnormal use, accident, improper installation or an attempt to repair equipment by anyone other than factory authorised personnel even when using MOBA Australia's certified or recommended parts, automatically voids the warranty.

The warranty shall only be in force for the benefit of the Purchaser, not any third parties, including without limitation the Purchaser's customers, unless warranty transfer has been approved by MOBA Australia in writing.

Warranty period:

Products	Warranty (months)
Laser receiving systems and components, visual guidance	12
Repairs and Replacements	
Repairs and replacements made under warranty	Warranty expires at the same time as original equipment warranty
Repairs made out of warranty	3

MOBA Australia or its authorised service centre will repair or replace, at its option, any defective part or component of which notice has been given during the warranty period. If service in the field is necessary to repair machine-mounted equipment under warranty, MOBA Australia may authorize on-site repairs at no charge for parts and labour. Travel time, accommodation and other expenses incurred to and from the place where repairs are made will be charged to the purchaser at the prevailing rates. If warranty service can be done at a factory authorised service centre, the customer will pay only one-way freight charges.

The foregoing states the entire liability of MOBA Australia regarding the purchase and use of its equipment. MOBA Australia will not be held responsible for any consequential loss or damage of any kind.

This warranty is in lieu of all other warranties, expressed or implied, except as set forth above, including any implied warranty of merchantability or fitness for a particular purpose which are hereby disclaimed.

SAFETY INFORMATION

Please become familiar with the important safety information in this section. Improper use or installation of the MOBA Laserguide may result in personal injury or damage to the receiver unit.



Read and become familiar with the manufacturer's operating manual for your machine, including safety information, before installing or using your Laserguide receiver.



A construction site can be hazardous and working around heavy construction equipment can be dangerous. Always exercise extreme caution when on a construction site.



The Laserguide bracket contains strong permanent magnets which can cause injury if not handled correctly. Always follow correct installation procedure outlined in this manual and always replace the magnetic bracket protective plate when unit is not attached to a machine.



The Laserguide is externally mounted on your machine. Do not install or adjust the unit while your machine is running.



Do not let any part of the unit protrude into traffic or limit the visibility of the operator.



Hydraulic lines can be under extreme pressure, even when the machine is not running. When working on or near hydraulic lines, protect yourself at all times and wear protective clothing.



This product contains batteries. Do not dispose of batteries or this product with normal household waste. To prevent possible harm to human health and the environment, batteries and electrical equipment must be collected and recycled separately according to local regulations.

TABLE OF CONTENTS

1. Features of the Laserguide	6
2. Using the Laserguide	8
2.1 Attaching and Removing the Unit from the Machine.....	8
2.2 Powering Up	8
2.3 Setting Up	9
2.3.1 Setting Up With Tilt Compensation On	10
2.3.2 Setting Up With Tilt Compensation Off	11
2.4 Compensation Range	11
2.5 Accuracy (Centre Band)	11
2.6 Buzzer	11
2.7 LED Brightness	12
2.8 Low Battery Warning	12
2.9 Replacing the Batteries.....	12
2.10 Powering via External Power Supply.....	12
3. Using With an Android Device.....	13
3.1 Connecting the Unit to an Android Device.....	13
3.1.1 Pairing R.45.TC.PRO	13
3.1.2 Pairing R.45.PRO-V2 & R.45.TC.PRO.....	14
3.2 Using the Android App.....	14
4. Using with DB.UNI.PRO Display Panel.....	15
4.1 Connecting the Unit to DB.UNI.PRO Display Panel via BT.....	15
4.2 Configuring BT on DB.UNI.PRO.....	16
4.3 Connecting DB.UNI.PRO via Wired CAN Connection	17
4.4 Using the DB.UNI.PRO Display Panel.....	18
5. Technical Specifications	19
6. Declaration of Conformity - R.45.TC	20
7. Declaration of Conformity - R.45.PRO-V2.....	21

1. FEATURES OF THE LASERGUIDE

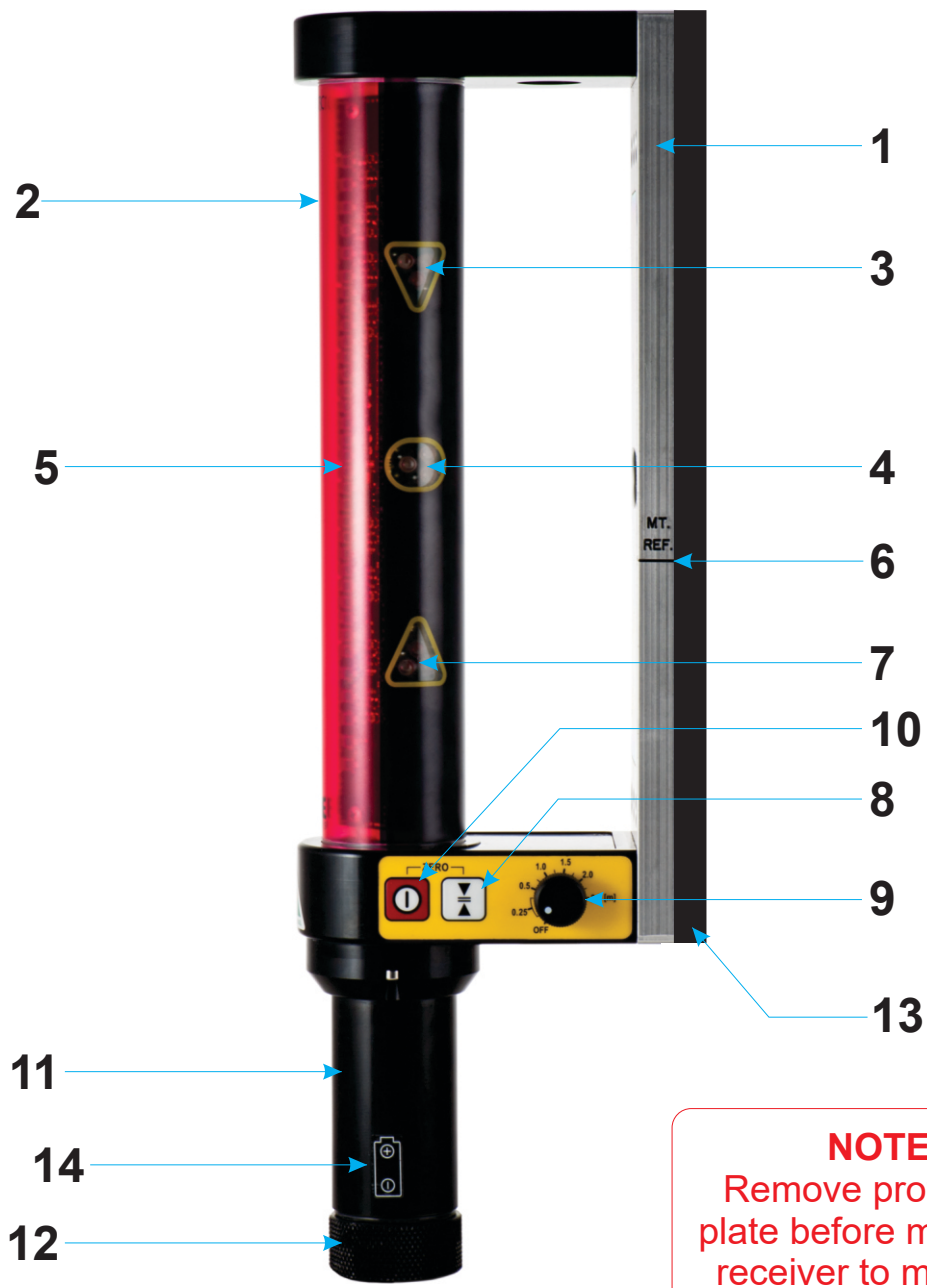

Figure 1.1
R.45.TC

- | | |
|--------------------------------|--|
| 1. Magnetic Bracket | 8. Accuracy Switch (Centre Band) |
| 2. Receiving Area | 9. Reference Dial |
| 3. Top LED Cluster (RED) | 10. On/Off Switch |
| 4. Centre LED Cluster (GREEN) | 11. Battery Compartment (Holding Handle) |
| 5. Power On LED | 12. Battery Cap |
| 6. Mounting Reference Mark | 13. Magnetic Bracket Protective Plate |
| 7. Bottom LED Cluster (ORANGE) | 14. Battery polarity marking |

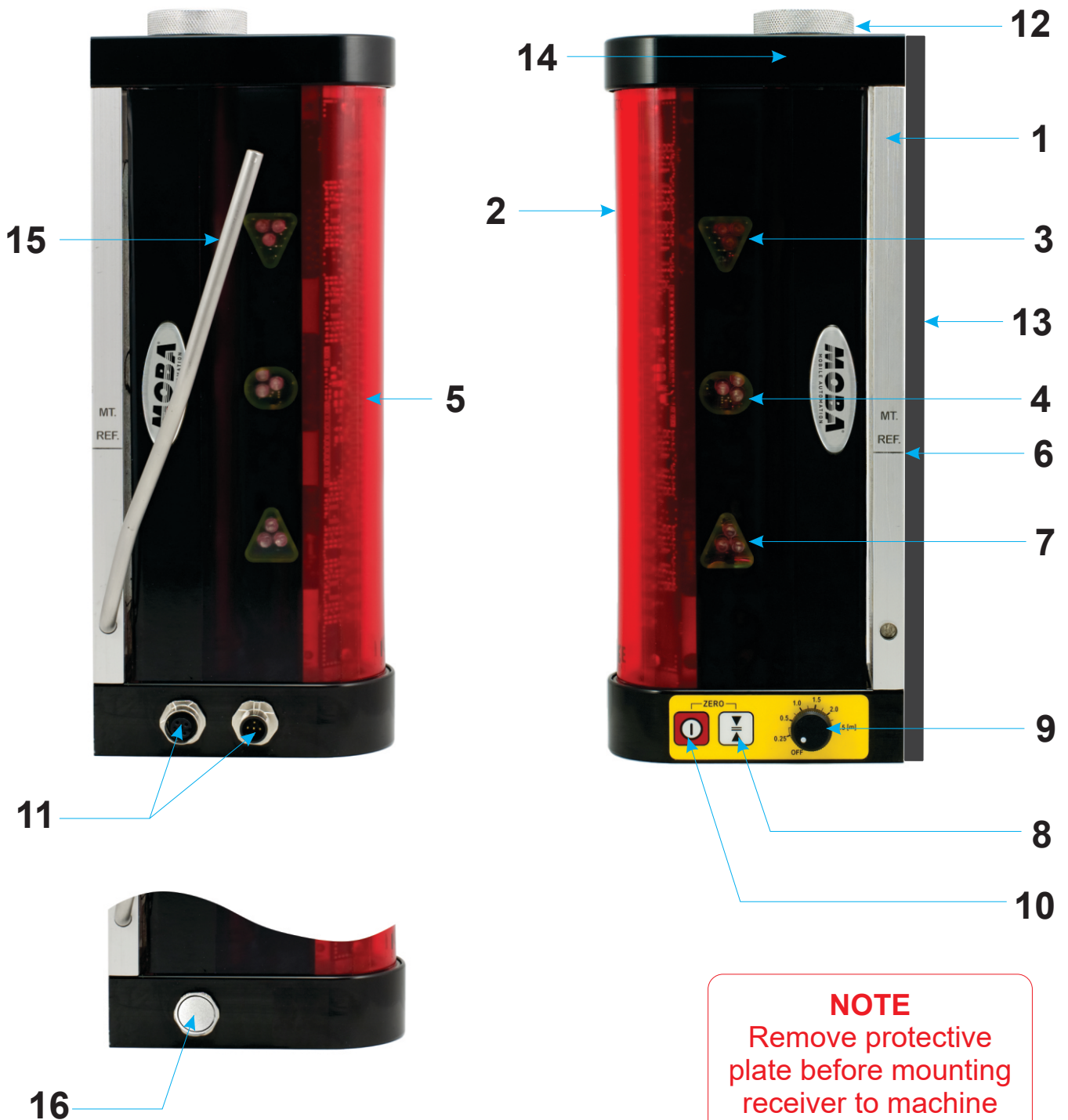

Figure 1.2

R.45.TC.PRO / R.45.PRO-V2

- | | |
|----------------------------------|--|
| 1. Magnetic Bracket | 9. Reference Dial |
| 2. Receiving Area | 10. On/Off Switch |
| 3. Top LED Cluster (RED) | 11. CAN Connectors (R.45.TC.PRO only) |
| 4. Centre LED Cluster (GREEN) | 12. Battery cap |
| 5. Power On LED | 13. Magnetic Bracket Protective Plate |
| 6. Mounting Reference Mark | 14. Battery polarity marking (inside battery tube) |
| 7. Bottom LED Cluster (ORANGE) | 15. Dismounting Lever |
| 8. Accuracy Switch (Centre Band) | 16. Pressure relief vent (R.45.PRO-V2 only) |

2. USING THE LASERGUIDE

2.1 Attaching and Removing the Unit from the Machine

The Laserguide bracket contains strong permanent magnets which can cause injury if not handled correctly. Always follow correct and safe installation procedure outlined here.

- Remove the magnetic bracket protective plate (12) from the unit ensuring there are no steel or other ferrous metal items in immediate vicinity of the unit.
- Carefully attach the Laserguide by first positioning it at the desired height away from the machine's arm, then bringing it toward the arm until the magnets engage.
- Take extreme care to avoid pinching any part of your body with the magnetic bracket.
- To remove the unit:
 - R.45.TC - grip the unit by the battery tube and pull away from the machine
 - R.45.TC.PRO & R.45.TC.PRO-V2 - pull on the dismantling lever to separate the unit from the machine
- Always re-place the protective plate on the magnetic bracket when unit is not attached to the machine.

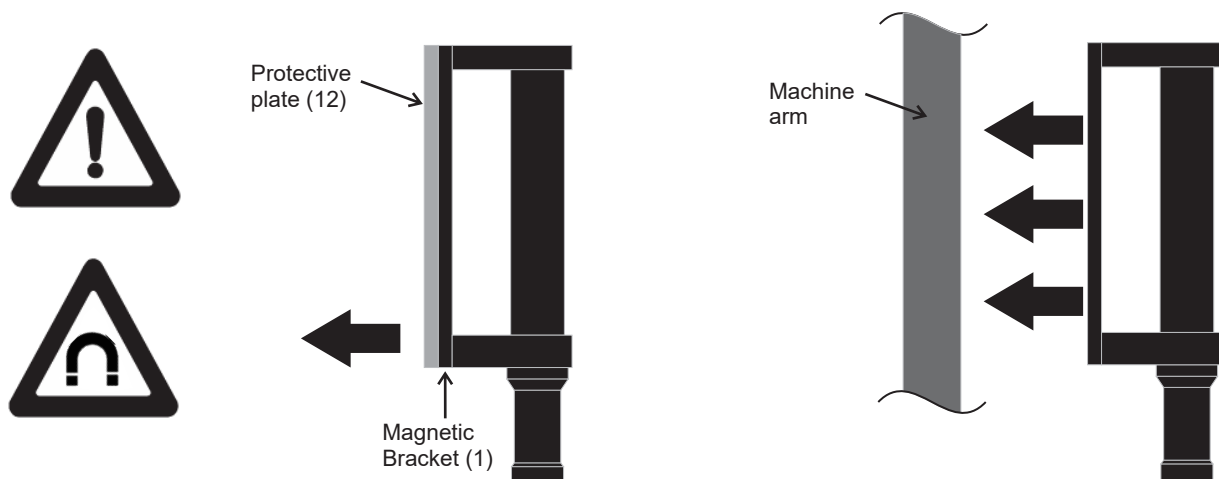

2.2 Powering Up

Press the On/Off switch (10) for 2 seconds to turn the unit on/off. The small red power-on LED (5) indicates the mode of operation as determined by the Reference Dial (9) position:

LED flashing – Tilt compensation feature is on. The unit automatically accounts for the dipper arm tilt to indicate correct digging depth. Reference Dial (9) not in Off position.

LED solid – Tilt compensation feature is off. The unit does not account for the dipper arm tilt when indicating correct digging depth. This mode is less accurate. Reference Dial (9) in Off position.

On power up, the sensor will do an LED test sequence, activating in turn the red, green and amber LEDs. It will then show the current accuracy selection by briefly flashing the appropriate LED pattern (see section 2.5).

2.3 Mounting and Setting Up

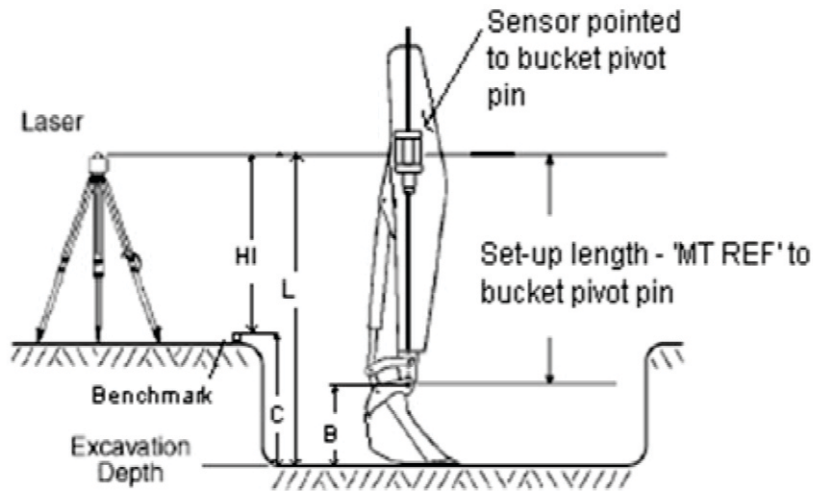

Figure 2.3.1 - IN-TRENCH SETUP

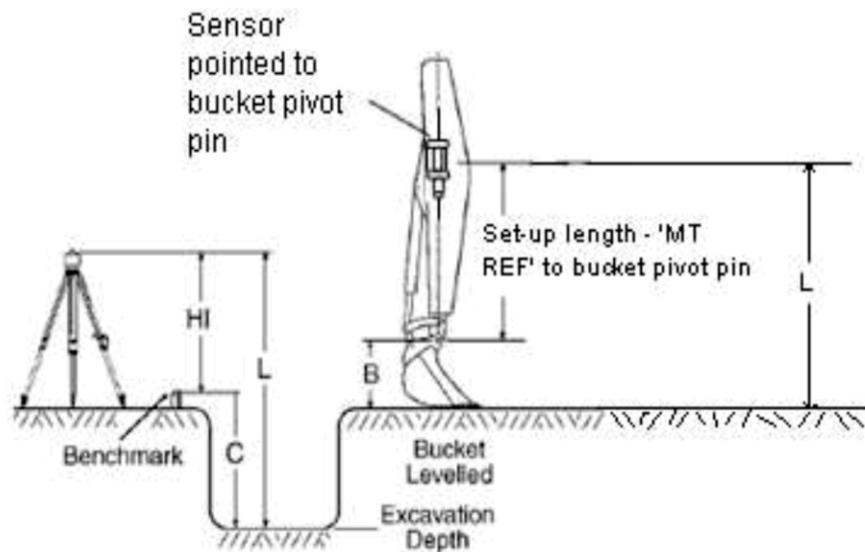

Figure 2.3.2 - OUT-OF-TRENCH SETUP

HI - Height of the laser instrument referenced to the benchmark.

C - Desired depth of cut or excavation referenced to the benchmark.

L - Height of the laser instrument referenced to the bottom of the trench.

B - Bucket height from bucket pivot pin to ground when the bucket is level

Setup Length - Distance from bucket pivot pin to 'MT REF' line mark on the side of the R.45.TC/R.45.TC.PRO magnetic bracket (relevant only when using tilt compensation).

With regard to above figures, refer to section 2.3.1 if intending to use the tilt compensation feature or to section 2.3.2 if intending NOT to use the tilt compensation feature.

2.3.1 Setting Up With Tilt Compensation On

1. Ensure the dipper arm is vertical and the bucket is level.
2. Set up the laser instrument on a steady tripod.
3. Mount the receiver unit on the dipper arm, following instructions in section 2.1 and such that the 'MT REF' (Mounting Reference) line mark on the side of the magnetic bracket is at a distance L from the ground. Distance L equals the height of the laser instrument (HI) plus the desired depth of excavation (C), both with respect to the benchmark:

$$L = HI + C$$

The long side of the receiver unit body should be parallel with the dipper arm and in line with the top and bucket pivot pins of the dipper arm. The switchpad should be orientated to the bottom.

4. Determine the Setup Length by measuring the distance between the bucket pivot pin and the 'MT REF' line on the magnetic bracket. This is the same as the mounting distance L minus the bucket height B:

$$\begin{aligned} \text{Setup Length} &= L - B \\ &= HI + C - B \end{aligned}$$

The Setup Length should lie within the receiver unit's working range of 0.25-2.5m. If it is outside of this range, lower or raise the height of the laser instrument (HI) and readjust the unit mounting position to bring it within range.

For best accuracy, the Setup Length should coincide with one of the selectable values on the dial, that is, 0.25m, 0.5m, 0.75m, 1m, 1.25m, 1.5m, 1.75m, 2m, 2.25m or 2.5m. For most applications, a Setup Length as close as possible to one of these values is adequate.

5. Turn the Reference Dial (9) to the measured Setup Length value or to the closest available value.
6. 'Zero' the setup position by pressing and holding together the Accuracy (8) and On/Off (10) switches. A successful 'zeroing' is acknowledged by a brief flashing of the green LED cluster and sounding of the buzzer. An unsuccessful attempt is indicated by a brief flashing together of the red and amber LED clusters. A failed attempt can be caused if the unit is angled too far from the vertical or if the Reference Dial (9) is in the off position.

IMPORTANT NOTE: Whenever the Reference Dial (9) value is changed to indicate a new Setup Length, 'zeroing' is required for the new value to take effect. Without 'zeroing', the previously 'zeroed' Setup Length remains in effect even though the dial may be turned to the new value.

The unit is now ready for use. With laser being received, the green LED cluster will indicate the correct digging depth for any dipper arm angle within the unit's compensation range (see section 2.4). Note that as the dipper arm swings, correct digging depth is achieved when the bucket orientation is in the level position.

2.3.2 Setting up With Tilt Compensation Off

1. Ensure the dipper arm is vertical and the bucket is level.
2. Set up the laser instrument on a steady tripod.
3. Ensure the Reference Dial (9) is in the Off position.
4. Mount the receiver unit on the dipper arm, following instructions in section 2.1 and such that the centre green LED cluster is at a distance L from the ground. Distance L equals the height of the laser instrument (HI) plus the desired depth of excavation (C), both with respect to the benchmark:

$$L = HI + C$$

The long side of the unit's body should be parallel with the dipper arm and the switchpad oriented to the bottom. After mounting, there is no need to measure the Setup Length or 'ZERO' the setup.

2.4 Compensation Range

When using with tilt compensation, the receiver compensates for up to:

Setup length (m)	Compensation (deg)	Setup length (m)	Compensation (deg)
0.25	± 42	1.50	± 19
0.50	± 31	1.75	± 17
0.75	± 26	2.00	± 16
1.00	± 23	2.25	± 15
1.25	± 20	2.50	± 14

If the dipper arm is tilted more than the compensation range whilst the unit is receiving a laser beam, the indication LEDs and buzzer will flash/buzz at a slower frequency to alert the user.

2.5 Accuracy (Centre Band)

The receiver has three accuracy (centre band) settings: Fine, Normal and Wide. The current setting is indicated by a brief flash of the corresponding LED pattern, as shown in the table below. This flash occurs on power-up (after the power-up sequence) or when the setting is changed. To change the setting, briefly press the Accuracy Switch (8).

SETTING	LED Cluster Pattern	ACCURACY
Fine	Green	+/- 4mm
Normal	Red & Orange	+/- 8mm
Wide	Red, Orange & Green	+/- 12mm

Table 2.5.1

2.6 Buzzer

To turn the buzzer on or off, press and hold the On/Off switch (10) until a single or double beep is heard - single beep indicates buzzer on, double beep indicates buzzer off.

2.7 LED Brightness

The unit has 3 brightness settings for the LEDs. To change brightness setting:

- Press and hold the accuracy switch (8) - LEDs indicating accuracy setting will light up
- While still holding the accuracy switch (8), briefly press the On/Off switch (10) to change between 3 different brightness levels

NOTE: you will need to revert the accuracy setting to what it was before brightness adjustment.

2.8 Low Battery Warning

If low battery is detected, the power-on LED will flash at a fast rate (not to be confused with the slower flashing rate indicating compensation mode is switched on). If a laser beam is on the receiving area at the time of low battery, the flashing frequency of the indication LEDs will slow and the buzzer will turn off to preserve power.

2.9 Replacing the Batteries

To replace the batteries:

- Unscrew the battery cap (12)
- Remove old batteries and dispose of correctly following local regulations. Do not dispose of batteries with normal household waste!
- Replace with:
 - 4 new C size alkaline batteries (R.45.TC.PRO & R.45.PRO-V2) or
 - 1 new D size alkaline battery (R.45.TC)
- Make sure to orientate the batteries correctly following the battery polarity markings (14) on the outside of the battery tube (R.45.TC) or inside of the battery tube (R.45.TC.PRO and R.45.PRO-V2)
- Replace and tighten the battery cap (12)

2.10 Powering via external power supply - R.45.TC.PRO Only

The R.45.TC.PRO can also be powered with 12-24 V DC external power supply as per following diagram.

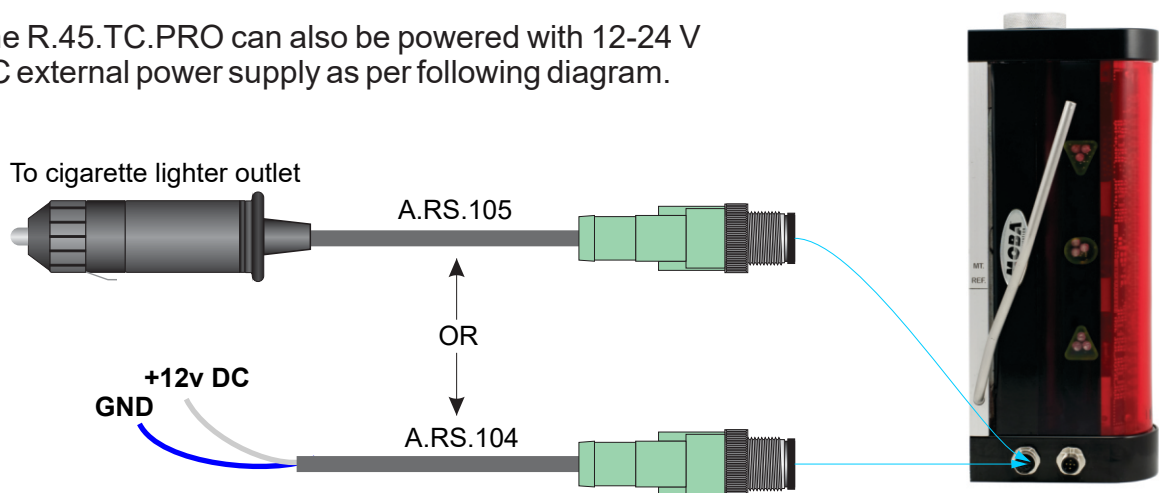

Figure 2.10.1

3. USING WITH AN ANDROID DEVICE (R.45.TC.PRO & R.45.PRO-V2)

The R.45.TC.PRO & R.45.PRO-V2 can communicate via BT with an Android based device via the R.45.TC.PRO App.

3.1 Connecting the unit to an Android device



Figure 3.1.1

Before proceeding with pairing procedure for your receiver model please:

- Download R.45.TC.PRO.APP to your Android device from Google Play or from moba.com.au/downloads. Please note the app is available only for Android devices.
- Ensure the receiver unit is in close proximity to the Android device and it is turned on

3.1.1 Pairing R.45.TC.PRO (with serial nos. up to and including 01288561)

1. Press and hold the On/Off switch (10) on the unit for 20 seconds until the sounding of 2 long beeps. This will put the unit into pairing mode.
2. Go into the Android device's BT setup, switch on the BT setting and select scan for devices. The name R45PRO will appear in the found devices list. Select pair with this device and enter 1234 when prompted for a password.
3. Open the R.45.TC.PRO App. At the bottom right hand side "R45PRO" will appear to indicate the unit is connected. If the words "NOT CONNECTED" appear repeat the above steps.

Once the App is connected it will start to mirror the receiver's height information. If this does not happen, close the app and re-open it. If setup fails, switch off the receiver unit, shut down the app and unpair the Android device from the receiver unit then repeat above steps.

3.1.2 Pairing R.45.PRO-V2 & R.45.TC.PRO (with serial nos. 01288562 and above)

1. Press and hold the power button for 20 seconds until 2 long audible beeps.
2. Wait for 5 seconds for the unit to configure the BT module and enter pairing mode.
3. On your Android device, select "R45PRO" from available devices in Bluetooth settings.
4. Wait for another 5 seconds until 2 short beeps play in quick succession to indicate the Bluetooth pairing sequence was complete.
5. Launch "MOBA PRO" app. The mobile device should connect to the laser receiver seamlessly and start receiving data.

3.2 Using the Android App

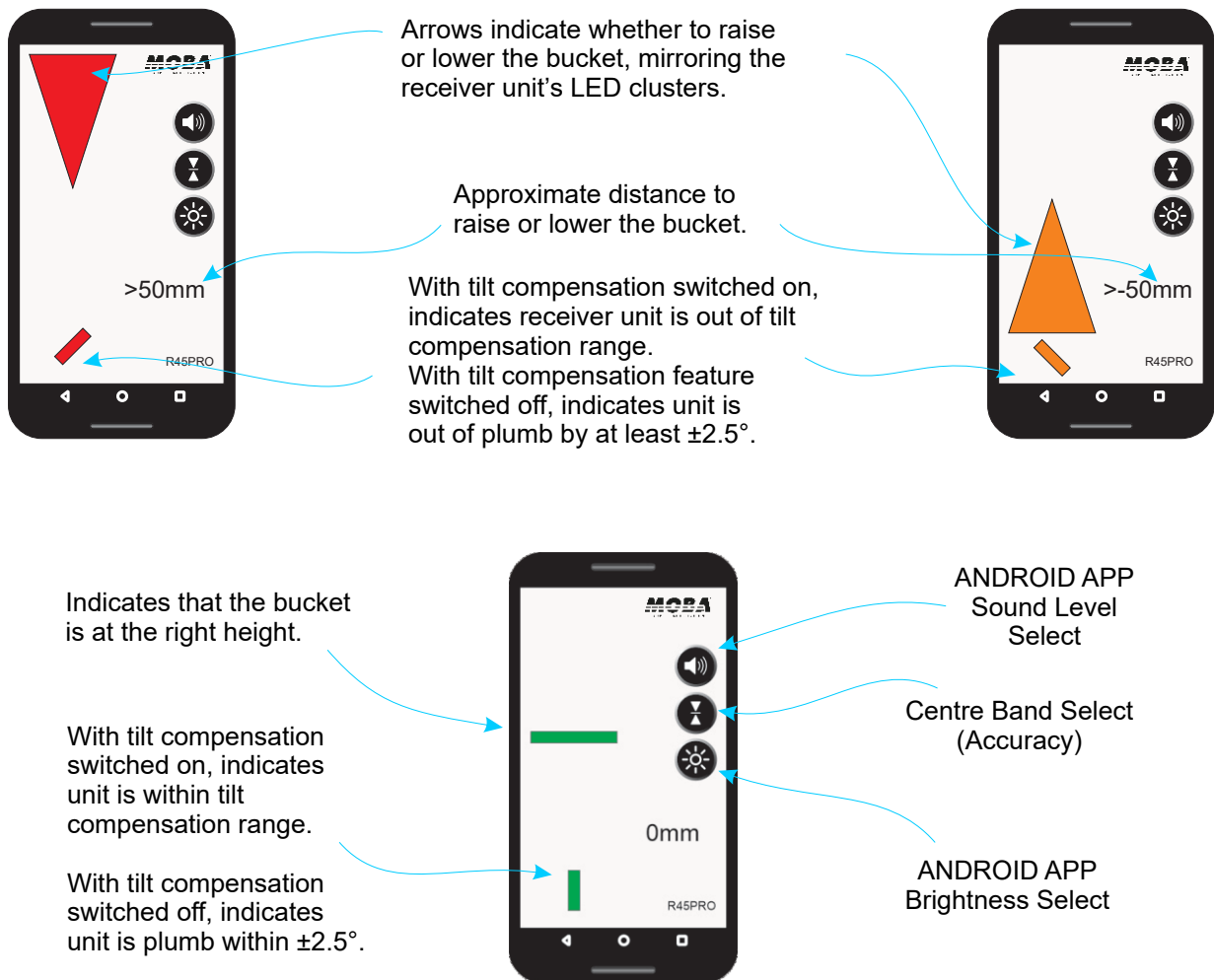

Figure 3.2.1

4. USING WITH DB.UNI.PRO DISPLAY PANEL (R.45.TC.PRO & R.45.PRO-V2)

The R.45.PRO-V2 can communicate with the DB.UNI.PRO display panel via BT while R.45.TC.PRO can communicate with DB.UNI.PRO via BT or wired CAN connection.

4.1 Connecting the unit to DB.UNI.PRO display panel via BT

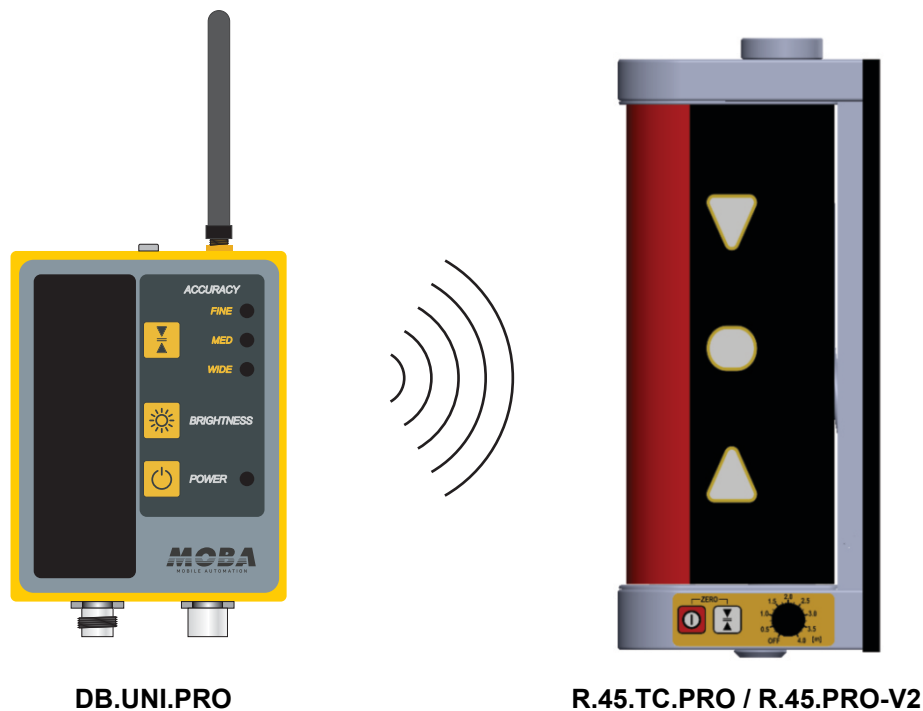

Figure 4.1.1

1. Ensure the receiver unit and DB.UNI.PRO are in close proximity to each other.
2. Switch on both the receiver unit and DB.UNI.PRO display panel.

The DB.UNI.PRO will automatically pair with the receiver unit and start to mirror its LED clusters. This may require up to 30 seconds the first time it is done. If the two do not establish communication, switch both off and on again and wait 30 seconds. See section 4.2 if this does not work.

4.2 Configuring BT on DB.UNI.PRO

The DB.UNI.PRO normally automatically pairs with the receiver unit on power up. In cases where the two are not communicating, the DB.UNI.PRO and/or the receiver unit may need to be configured using the following steps:

1. Ensure the DB.UNI.PRO and receiver unit are in close proximity to each other.
2. Switch off both the DB.UNI.PRO and the receiver unit.
3. Press and hold the On/Off button (10) on the receiver unit for 20 seconds until two long beeps sound.
4. Switch on the DB.UNI.PRO and wait for 30 seconds. Communication should be re-established.

If this fails, follow the following steps:

5. Ensure DB.UNI.PRO and receiver unit are in close proximity to each other.
6. Switch off the DB.UNI.PRO and switch on the receiver unit.
7. Press and hold the On/Off button on the DB.UNI.PRO for 10 seconds until a second beep sounds.

A progressive LED arrow bar indication will begin to flash to indicate the DB.UNI.PRO is in BT configure mode. After a short period, two LED straight bars will appear and flash in alternate sequence to show the BT is being setup and that the instrument is in search mode. Finally two LED straight bars will flash together on the DB.UNI.PRO to show the BT is setup and an active device has been found and is in progress of pairing. After a short period, the DB.UNI.PRO will start to communicate with the receiver unit.

If an X flashes on the DB.UNI.PRO, switch the DB.UNI.PRO off and on and wait 30 seconds. Repeat the above steps. If setup fails again, switch off the DB.UNI.PRO and then press and hold the On/Off button (10) on the receiver unit for 20 secs until 2 long beeps sound. Repeat step 3.

Note: These settings will be saved and not required to be repeated once successfully setup.

4.3 Connecting DB.UNI.PRO via wired CAN connection (R.45.TC.PRO only)

1. Using the supplied CAN cable, connect between the male connector of the DB.UNI.PRO and the female connector of the R.45.TC.PRO.
2. Using the supplied power cable, connect the '12-24V DC' female connector of the DB.UNI.PRO to an external 12-24V DC power supply, such as a car or excavator battery.
3. Press the On/Off button on the DB.UNI.PRO to switch both units on.

Once the units are powered on, the DB.UNI.PRO will automatically start displaying the receiver's height information.

Cable Options:

CAN Cables (DB.UNI.PRO to R.45.TC.PRO)

- A.RS.103, 7.5m
- A.RS.102, 5m

Power Cables

- A.RS.104, 5m, Free Wires
- A.RS.105, 5m, Cigarette Lighter

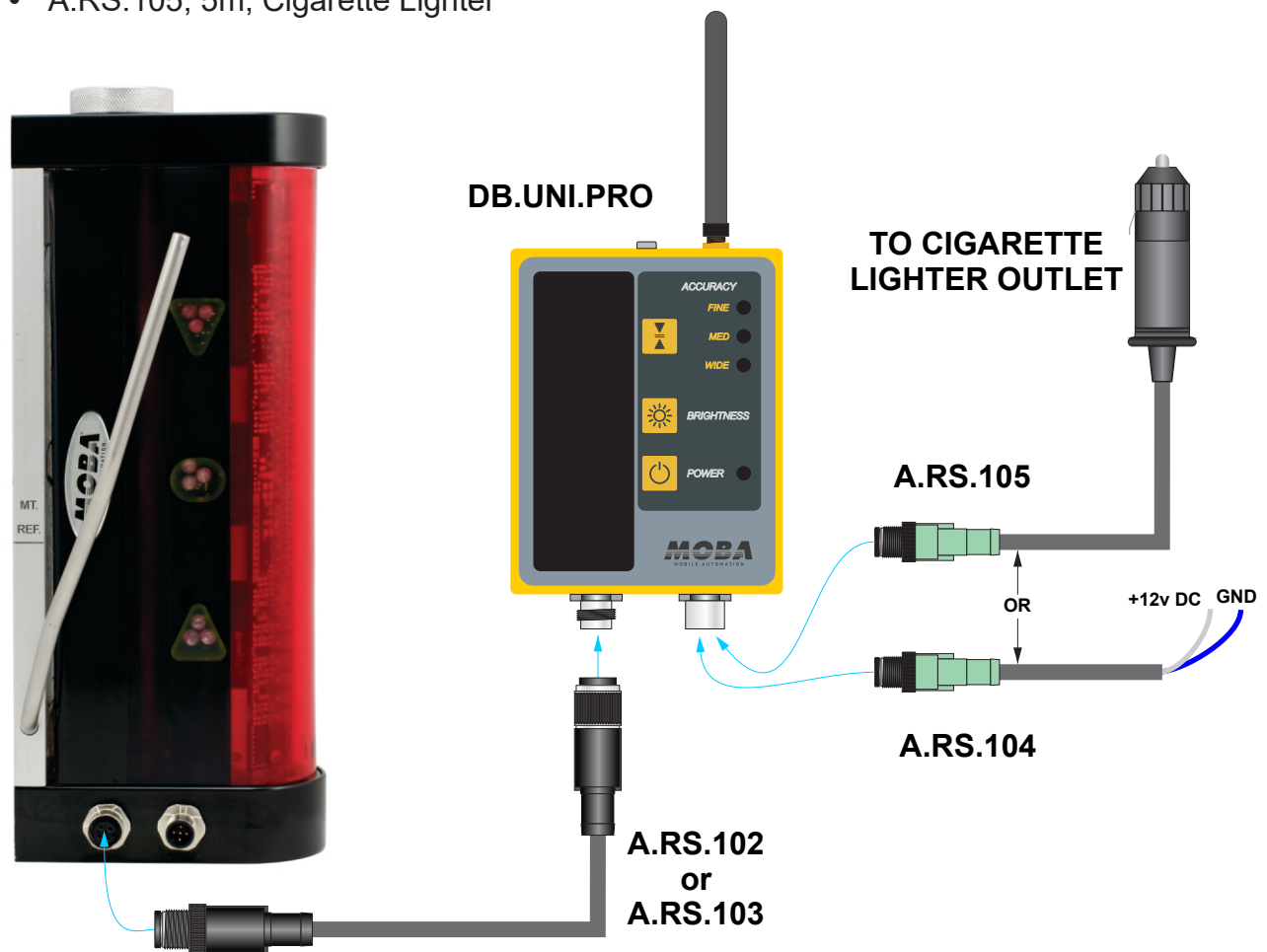

Figure 4.3.1

4.4 Using the DB.UNI.PRO Display Panel

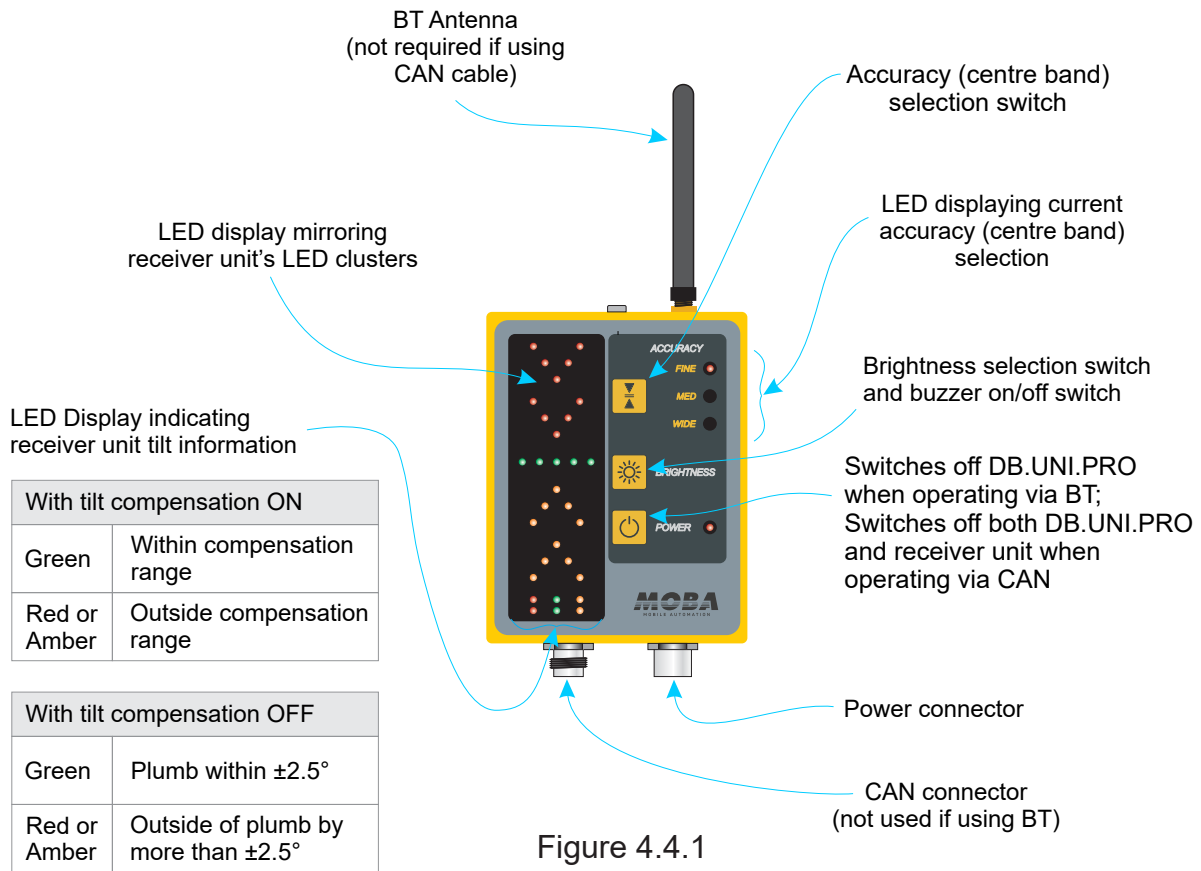

Figure 4.4.1

The receiver's centreband can be changed via the Centre Band Select button on the DB.UNI.PRO. The current centreband selection is shown via the lit LED next to one of 'FINE', 'NORMAL', or 'WIDE'.

The DB.UNI.PRO's LED brightness level can be changed via the Brightness Select button. One of five brightness levels can be selected.

Pressing and holding the Brightness Select button for 3 seconds will switch the DB.UNI.PRO buzzer on and off.

5. TECHNICAL SPECIFICATIONS

	R.45.TC	R.45.TC.PRO	R.45.PRO-V2	DB.UNI.PRO
Receiver Area Length	190 mm			N/A
Receiving Range (Radius) ¹	600 m			N/A
Beam Reception Angle	220°			N/A
Max Centre Band Resolution	+/- 4mm			N/A
Compensation Range ²	Up to 42°			N/A
Height Indication	Inbuilt Colour-Coded LED Clusters			
Battery Type	1 x D Size Alkaline	4 x C Size Alkaline		N/A
External Power Supply	N/A	12-24 V DC	N/A	12-24 V DC
Operating Time	45 hours ³	70 hours ³		N/A
Waterproof ⁴ / Dustproof	Yes / Yes			No / Yes
Dimensions (L x W x H)	390 x 69 x 117 mm	296 x 69 x 116 mm	308 x 70 x 118 mm inc. BT antenna	120 x 95 x 35 mm ⁵
Weight	1.9 kg	2.1 kg	2.2 kg	0.4 kg
Mounting	Integrated Magnetic Clamp			RAM Ball
BT Connectivity	No	Yes		
CAN Connectivity	No	Yes	No	Yes

Table 6.1

Specifications subject to change without further notice.

1. Tested with VIS.2NA laser transmitter.
2. Dependent on mounting distance from bucket pivot pin.
3. With buzzer off and continuous laser beam reception.
4. Submersed to 20cm.
5. Excluding connectors, RAM mount ball and antenna.



KONFORMITÄTSERKLÄRUNG

Declaration of Conformity Déclaration de Conformité

This corresponds to EN ISO/IEC 17050-1

Wir / We / Nous

MOBA Mobile Automation Australia PTY LTD
90 Willandra Drive, Epping 3076, Victoria, Australia.

*erklären in alleiniger Verantwortung, dass das Produkt
declare under our sole responsibility that the product
déclarons sous notre seule responsabilité que le produit*

R.45.TC Laser receiver with tilt compensation

*auf das sich diese Erklärung bezieht, mit den folgenden Normen übereinstimmt
to which this declaration relates is in conformity with the following standards
auquel se réfère cette déclaration est conforme aux normes*

ISO 13766-1:2018

Verified Standards:

EN 55022:2008-05
EN 13309:2010, ISO 11452-3:2001
EN 61000-6-2, EN 61000-4-2:2009

*gemäß den Bestimmungen der Richtlinie
following the provisions of Directive
conformément aux dispositions de Directive*

Directive 2014/30/EU of the European Parliament and of the Council C/2019/5759

Date: **24.06.2021**

Signature and/or Company Seal:



Signed by:

Daniel Ramondetta
Managing Director
MOBA Mobile Automation Australia PTY LTD

MOBA Mobile Automation
Australia PTY LTD
ABN-866 279 713 68
90 Willandra Drive
Epping 3076
Victoria, Australia
P: +61 3 9357 0055
E: aumoba@moba.de
www.moba-automation.com.au

MOBA[®]
MOBILE AUTOMATION

**KONFORMITÄTSERKLÄRUNG****Declaration of Conformity
Déclaration de Conformité**

This corresponds to EN ISO/IEC 17050-1

*Wir / We / Nous***MOBA Mobile Automation Australia PTY LTD
90 Willandra Drive, Epping 3076, Victoria, Australia.**

*erklären in alleiniger Verantwortung, dass das Produkt
declare under our sole responsibility that the product
déclarons sous notre seule responsabilité que le produit*

R.45.PRO-V2 Laser Receiver with Tilt Compensation and Bluetooth Interface

*auf das sich diese Erklärung bezieht, mit den folgenden Normen übereinstimmt
to which this declaration relates is in conformity with the following standards
auquel se réfère cette déclaration est conforme aux normes*

Verified Standards:

**EN ISO 13766-1:2019-04
ISO 11452-2 Edition 2004-11
EN 61000-4-2 Edition 2009-12
EN IEC 62368-1:2020+A11:2020
ETSI EN 300 328 V2.2.2
EN IEC 63000:2018**

*gemäß den Bestimmungen der Richtlinie
following the provisions of Directive
conformément aux dispositions de Directive*

**Directive 2014/30/EU of the European Parliament and of the Council C/2019/5759
Directive 2014/53/EU of the European Parliament and of the Council of 16 April 2014
Directive 2011/65/EU of the European Parliament and of the Council of 8 June 2011**

Date: 28.01.2026*Signature and/or Company Seal:**Signed by:*

Daniel Ramondetta
Managing Director
MOBA Mobile Automation Australia PTY LTD

MOBA Mobile Automation
Australia PTY LTD
ABN-866 279 713 68
90 Willandra Drive
Epping 3076
Victoria, Australia
P: +61 3 9357 0055
E: aumoba@moba.de
www.moba-automation.com.au

MOBA[®]
MOBILE AUTOMATION



Supplier's Declaration of Conformity FCC § 2.1077

Product Identification

Product Name: R.45.PRO-V2 Laser Receiver with Tilt Compensation and Bluetooth Interface
Model Number: R.45.PRO-V2
Product Type: Industrial electronic sensor with Bluetooth interface

Manufacturer

MOBA Mobile Automation Australia PTY LTD
90 Willandra Drive, Epping 3076, Victoria,
Australia

Responsible Party (FCC – United States)

MOBA Corporation
1000 MOBA Drive
Peachtree City
Georgia 30269, USA

FCC Compliance Statement

This device complies with Part 15 of the FCC Rules.
Operation is subject to the following two conditions:

1. This device may not cause harmful interference.
2. This device must accept any interference received, including interference that may cause undesired operation.

The R.45.PRO-V2 has been evaluated for compliance with **47 CFR Part 15 Subpart B** (Unintentional Radiators). The product incorporates an FCC-certified Bluetooth module (u-blox NINA-B221), which has been integrated in accordance with the module manufacturer's instructions and approved antenna configuration. Radiated emissions of the host device have been assessed through engineering evaluation supported by calibrated EMC testing. Based on this assessment and the documented integration of the certified radio module, the product is determined to comply with the applicable FCC requirements.

MOBA Mobile Automation
Australia PTY LTD
ABN-866 279 713 68
90 Willandra Drive
Epping 3076
Victoria, Australia
P: +61 3 9357 0055
E: aumoba@moba.de
www.moba-automation.com.au





Applicable FCC Rules

47 CFR Part 15, Subpart B – Unintentional Radiators

Declaration

I hereby declare that the equipment identified above has been shown to comply with the applicable requirements of **47 CFR Part 15**, and that the information contained in this declaration is accurate and complete to the best of my knowledge.

Signature

Signed for and on behalf of:

MOBA Mobile Automation Australia PTY LTD

Name: Daniel Ramondetta

Title: Managing Director

Place: Melbourne, Australia

Date: [05-02-2026]

Signature: 

